



Black Market Audio Live is:

Arjo : keyboard, samples/deck (on stage)
 Bert : guitar, laptop (on stage)
 Ton : vj-visuals (on stage or elsewhere)

Specs Front-Of-House PA mixing desk

Keyboards, guitar, microphone, laptop, decks are all mixed on stage by Arjo and Bert. For front-of-house PA mixingdesk is a stereo-out (L/R by jack + DI) available.

Specs monitor stage

Arjo and Bert don't use any (own) amps on stage. Keyboards, guitar and samples need to be heard loud by monitorsystem on stage. Same mix as FOH mixing desk.

And also:

- 8x 220 V (near stage-mixer)
- 1x microphone stand + boom + clip + microphone + XLR-cable
- 2x DI + 2x cable jack-DI

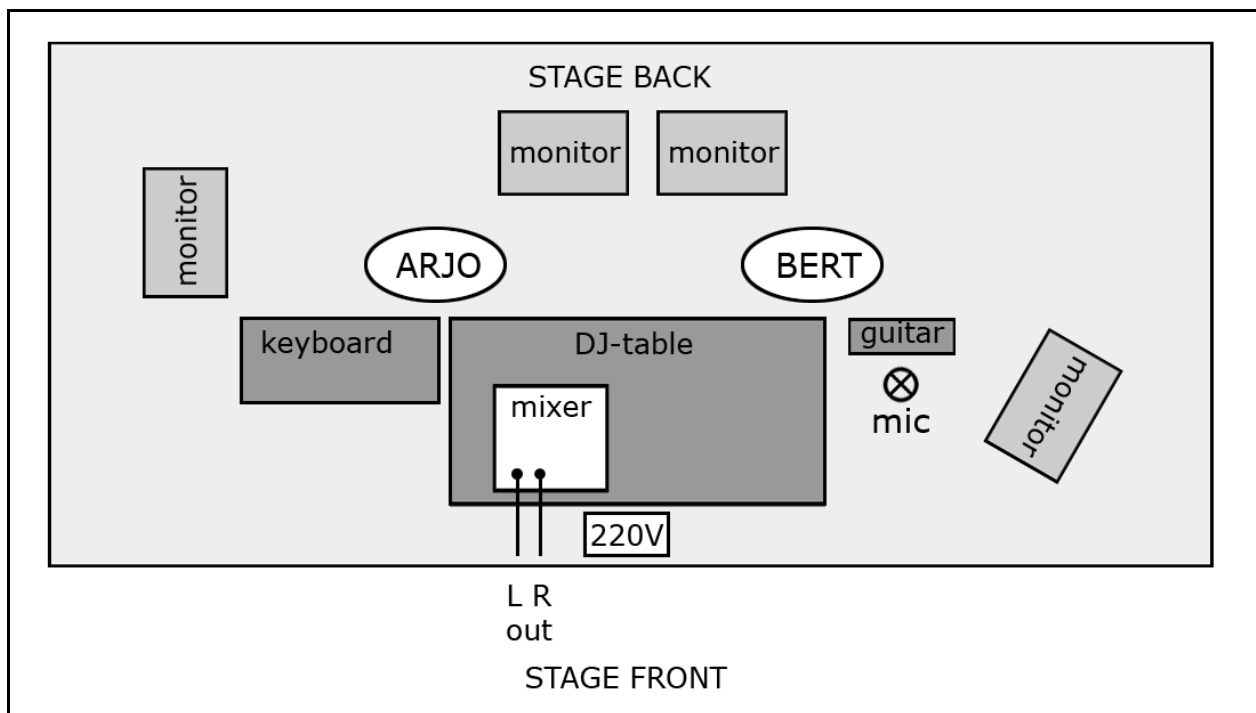

Contact:

Bert (030-2948738 or 06-49624549) or bert@blackmarketaudio.com
 Arjo (06-28160651)

Specs for BMA-vj (contact Ton: 06-25528199)

- Ton brings along his own laptop + videomixer
- Videobeamer (>1000 Ansi-Lumen)
- Projectionsscreen (preferable 300x400 cm) behind/above the stage
- Table (1.10 m high or more)
- Cable from table (videomixer) to the videobeamer